

DKH-4L

Technical Data

Hammer Model	DKH-4L
--------------	--------

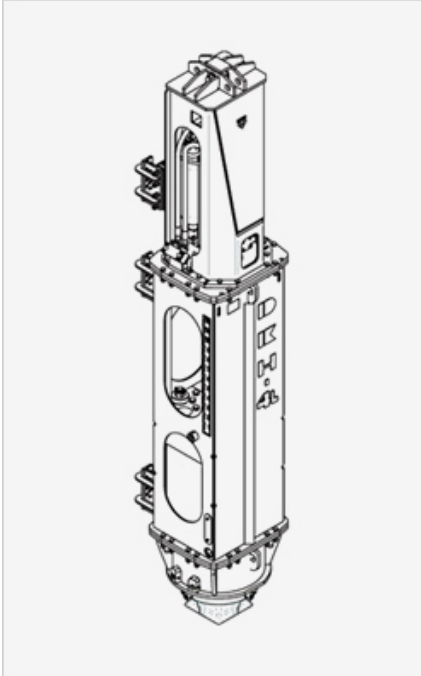

Operating Data

Max Potential Energy	Ton.m	4.8
	lb.ft	35,000
Max Stroke	mm	1,200
	ft	4
Min Stroke	mm	200
	ft	0.7
Blow rate at max stroke	bpm	40

Weight

Ram	Ton	4
	Lb	8,800
Hammer (with out drive cap)	Ton	8.3
	Lb	18,260
Drive cap	Ton	-
	Lb	-

Dimension

Length	mm	5,620
	ft	18.4
Width	mm	970
	ft	3.2
Height	mm	1,060
	ft	3.5

Hydraulic

Required operating pressure	bar	280
	psi	4,000
Required oil flow	lpm	190
	gpm	50

Power pack

Model	P-20	
Engine	HP	190
	kw	141

Guide pipe pitch*dia

Standard	mm	600x100
	ft	-
Option	mm	-
	ft	-

철달기